

Pro-CT MK II

04-410



The Pro-CT mk II phantom can be used for carrying out acceptance and constancy tests of computed tomography systems according to IEC 61223-3-5 and the AAPM (American Association of Physicists in Medicine) guidelines. This phantom consists of several test modules placed inside a cylindrical container that can be mounted either directly on a holder of the CT table or on an adjustable stand. It allows accurate alignment for measurements on and off the table. Markings on the phantom and leveling aids provide further facilitation of the positioning process.

The Phantom can be used to do the following tests:

- geometric distortion
- CT number (HU) measurement
- noise / uniformity
- artefacts
- MTF
- SSP, LSF, PSF
- CNR
- spatial resolution
- spatial resolution in Z dimension
- contrast resolution
- low contrast resolution
- slice profile
- alignment
- linearity
- beamwidth

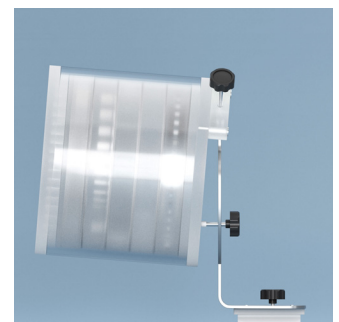
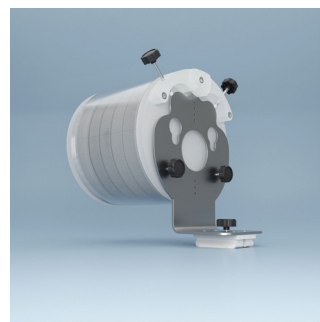



Adjustable in two dimensions.

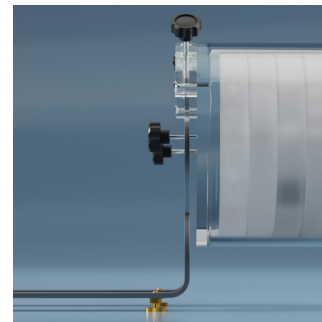
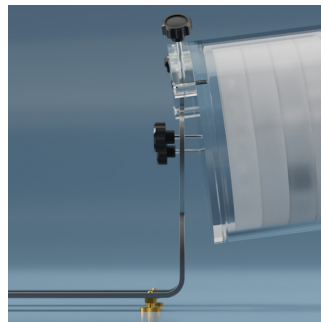
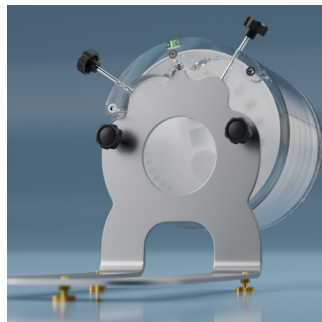
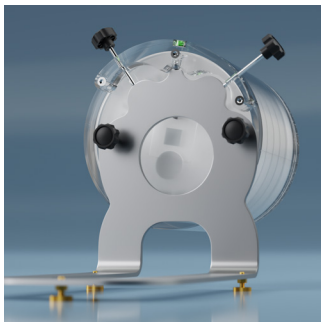

Technical data (can be modified to customer specifications):

- main module contains a PMMA section with an array of holes 2 mm in diameter, 10 mm deep, placed at 10 mm intervals
- outside diameter 220 mm
- length 250 mm
- optional external beam hardening rings:
 - 380 mm outside diameter (04-417)
 - 350 mm outside diameter (04-418)
 - 300 – 380 mm outside oval diameter (04-419)
 - 450 – 550 mm outside oval diameter (04-420)
- positioning stand for on and off table measurements
- carrying case

Low contrast module



- diameter: 200 mm
- thickness 30 mm
- made of PMMA
- contains three groups of low-contrast objects: in each group, there are rods of the same density, 20 mm in height and with a diameter ranging from 1 to 15 mm. Contrast difference between groups and surrounding material is 0.3, 0.6 and 1%
- optional subslice targets having a nominal 1.0% contrast and z-axis lengths of 3, 5, and 7 mm. For each of these lengths, there are objects of 3, 5, 7 and 9 mm in diameter (04-411)

Sensitometric / contrast module



- diameter: 200 mm
- thickness: 30 mm
- contains 9 sensitometric samples shaped like rods (\varnothing 25 mm): PTFE, LDPE, POM-C, ABS, PA-6, PET, air, plastic water equivalent and PMMA – modules body



Geometry module



- diameter: 200 mm
- thickness 30 mm
- contains two pairs of aluminium wire ramps whose slope angle tangent is equal to 0.5
- middles of ramps intersect on the same plane allowing very precise evaluation of the slice location
- contains 8 rods from the air in the vertices of the regular octagon close to the outer perimeter of the phantom for evaluating symmetry and circular geometry
- optional nine spheres to evaluate the scanner's imaging of subslice spherical volumes, diameters: 1.0, 2.0, 3.0, 4.0, 5.0, 6.0, 7.0, 8.0 and 9.0 mm (04-413)

Spatial / high contrast module



- diameter: 200 mm
- thickness: 30 mm
- contains 13 concentrically placed high contrast elements for spatial resolution evaluation from 1 to 13 LP/cm
- two tungsten carbide beads $\varnothing 0.18$ mm and $\varnothing 0.28$ mm for MTF and SSP calculation
- Linear Spread Function (LSF) PTFE / PMMA interface
- Point Spread Function (PSF) - 0.25 mm stainless steel wire in air
- optional, additional concentrically placed high contrast elements for spatial resolution evaluation from 14 to 30 LP/cm (04-414)

Pro-Water module



- diameter: 200 mm
- thickness 30 mm
- mimics true water within 1% accuracy

Optional electron density module (04-416)



- diameter: 200 mm
- thickness: 30 mm
- module made of PMMA
- contains samples of 10 different rod-shaped materials (25 mm diameter) with the known physical and electron density corresponding to the following tissues: lungs (inhale), lungs (exhale), breasts (50:50), dense bone, bone marrow, liver, muscles, adipose tissue; additionally, a sample with water and an optional titanium rod

Product features:

- complies with:
 - IEC 61223-3-5
 - IEC 61223-2-6
 - AAPM guidelines
 - ACR guidelines
 - 21CFR 1020.33 specifications
- the Manual provides detailed guidelines for carrying out each test, results assessment and registration